

DIMENSIONI D'INGOMBRO - OVERALL DIMENSIONS

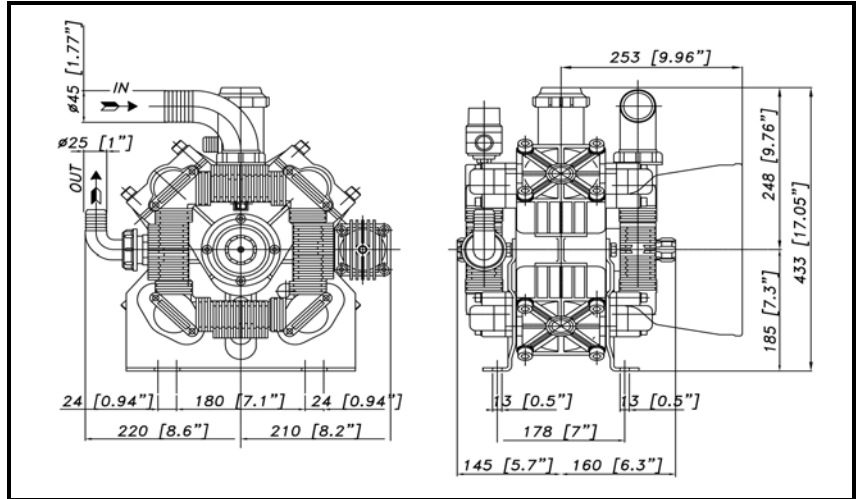

ALBERO POMPA - PUMP SHAFT

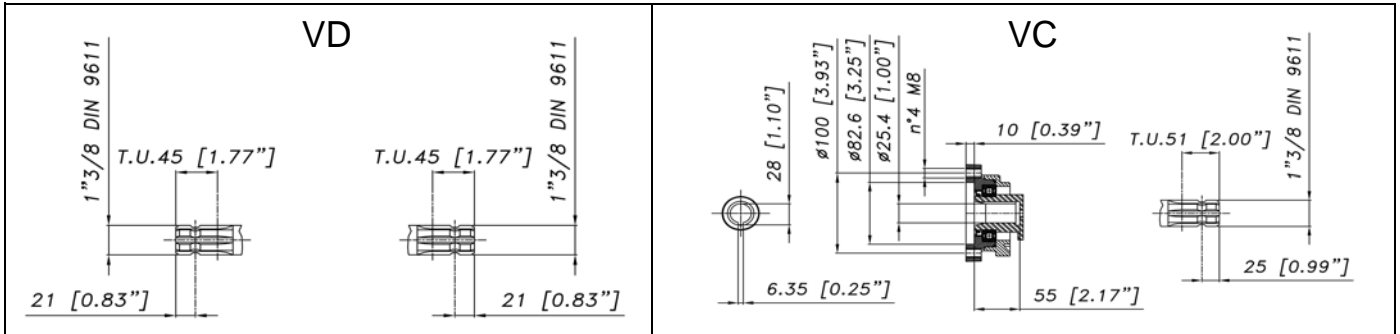

COPPIA DI SERRAGGIO - TORQUE CHART

CODICE - CODE	Q.TY	POS	N-m	Lbr.ft
62.9811.97.3	4	48	25	18,4
86.2216.00.2	2	6	8 (LOXEAL 24-18)	5,9 (LOXEAL 24-18)
86.3694.50.2	1	20	40	29,5
85.2562.50.2	2	17	5 (LOXEAL 24-18)	3,7 (LOXEAL 24-18)
86.2562.50.2	4	43	22	16,3
86.2682.50.2	2	46	22	16,3
86.2960.00.2	16	20	10	7,4
86.3277.00.2	6	61	40	29,5
86.4068.00.2	20	65	40	29,5

Tolleranza di serraggio: 0/-10%  
Tolerance on torque value:

INFORMAZIONI UTILI  
USEFUL INFORMATION

LUBRIFICANTE- LUBRICANT:				
OLIO MOTORE O SEMIIDRAULICO SAE 30 MOTOR OIL OR SEMI-HYDRAULIC OIL SAE 30				
PRESSIONE ACCUMULATORE ACCUMULATOR PRESSURE				
PRESSIONE DI LAVORO - OPERATING PRESSURE	2 ÷ 5	5 ÷ 10	10 ÷ 20	20 ÷ 50
ACCUMULATORE ACCUMULATOR	2	2 ÷ 5	5 ÷ 7	6 ÷ 8

KIT MEMBRANE - DIAPHRAGMS KIT

KIT	28.9886.97.3	BUNA - N			28.9887.97.3	DESMOPAN			28.9889.97.3	VITON					28.9897.97.3	PENTAX		
		1	31	12		1	31	12		1	31	12	33	22		23	15	1
POSIZIONE ESPLOSO POSITION NUMBER																		
QUANTITA' NEL KIT QUANTITIES INCLUDED	4	8	1	4	8	1	4	8	1	1	1	1	1	4	8	1		

KIT POMPA/KIT VALVOLE - PUMP KIT/VALVES KIT

KIT	28.9883.97.3	KIT POMPA VD PUMP KIT VD					28.9902.97.3	KIT POMPA VC PUMP KIT VC					28.9884.97.3	KIT VALVOLE VALVES KIT			28.9885.97.3	VALVOLE INOX VALVES KIT		
		22	31	34	41	33		22	31	33	41	34		77	75	2		31	33	2
POSIZIONE ESPLOSO POSITION NUMBER																				
QUANTITA' NEL KIT QUANTITIES INCLUDED	8	8	2	1	4	8	8	4	1	1	1	1	8	8	4	8	8	4		

# POLY 2180 VD (1"3/8 M-M)

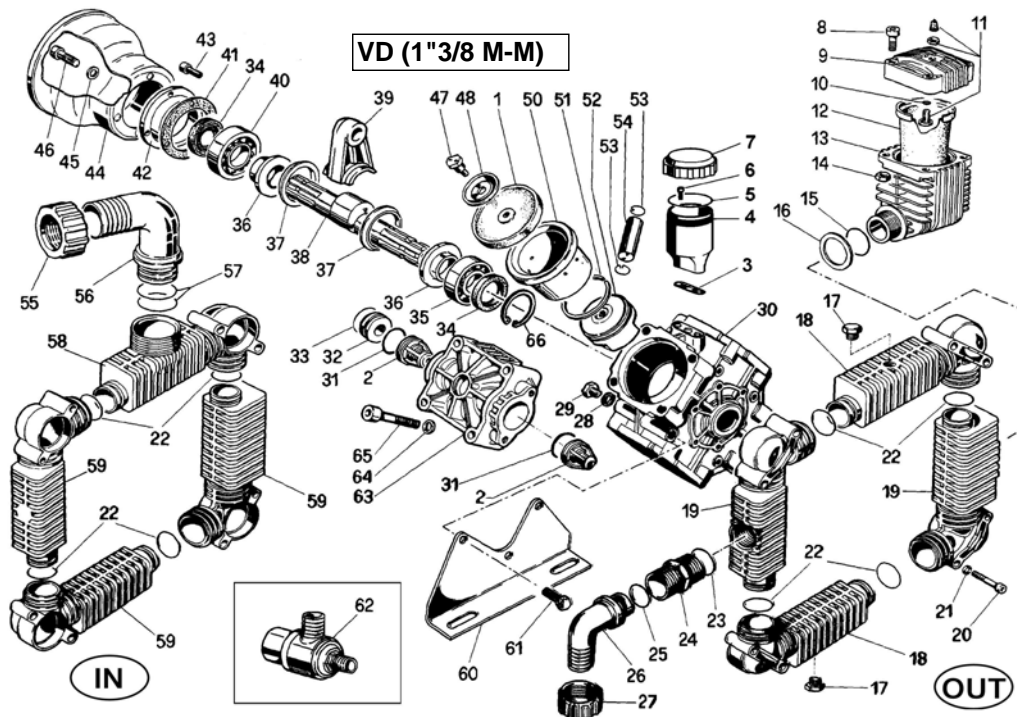

## VERSIONI

### VC (1"3/8 - D.1" M-F)

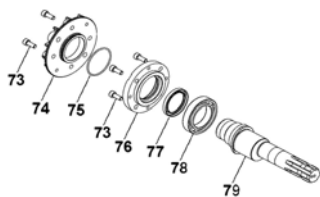

POS.	CODICE PART NO. REF.	DENOMINAZIONE - DESCRIPTION - DESCRIPTION	Q.TY	POS.	CODICE PART NO. REF.	DENOMINAZIONE - DESCRIPTION - DESCRIPTION	Q.TY
1	62.0040.31.2	PISTON DIAPHRAGM	4	33	80.3209.40.2	O-RING 2,62x44,12	4
1	62.0040.00.2	DESMOPAN PISTON DIAPHRAGM (OPT.)	4	33	80.3209.50.2	O-RING 2,62x44,12 (KIT VITON)	4
1	62.0040.33.2	VITON PISTON DIAPHRAGM (OPT.)	4	34	80.2143.10.2	OIL SEAL DIA.35x52x7	2
1	62.0040.36.2	HPS PISTON DIAPHRAGM (OPT.)	4	35	81.2846.00.2	BEARING DIA.35x72x17	1
2	28.9809.97.3	S.S. VALVE ASSY	8	36	28.0027.09.2	SHAFT SPACER	2
2	63.9800.97.3	POLYPROPYLENE VALVE ASSY (OPT.)	8	37	98.0047.76.2	CONNECTING ROD RING	2
3	14.0017.72.2	GASKET	1	38	62.0024.26.2	CRANKSHAFT "VD"	1
4	14.0012.32.2	OIL FILLER	1	39	28.0033.11.2	CONROD	4
5	80.3109.20.2	O-RING 1.8x67	1	40	81.2867.00.2	BEARING DIA.35x80x21	1
6	86.2216.00.2	SCREW M6x25	2	41	98.0110.72.2	GASKET	1
7	28.0144.32.2	OIL FILLER CAP	1	42	98.0108.09.2	COVER	1
8	86.2752.10.2	SCREW M8x35 UNI5931	4	43	86.2562.50.2	SCREW M8x20 UNI5931	4
9	11.0004.09.2	BALLASTER COVER	1	44	31.1482.32.2	PLAIN SAFETY CONE L=180 (OPTIONAL)	1
10	80.3213.00.2	O-RING 3,0x6	1	44	31.1468.32.2	PLAIN SAFETY CONE L=135 (OPTIONAL)	1
11	86.1608.50.2	AIR VALVE	1	45	84.3710.00.2	WASHER DIA.8,5x24x2	4
12	23.0041.31.2	BALLASTER DIAPHRAGM	1	46	86.2682.50.2	SCREW M8x25 UNI5931	4
12	23.0041.33.2	VITON BALLASTER DIAPHRAGM (OPT.)	1	48	62.9811.97.3	KIT SCREW/DISK INOX	4
12	23.0041.36.2	HPS BALLASTER DIAPHRAGM (OPT.)	1	50	62.0019.01.2	PISTON SLEEVE	4
13	27.0035.32.2	DAMPER BODY	1	51	81.8540.00.2	PISTON RING DIA.78	4
14	81.4574.50.2	NUT M8 UNI5588	4	52	62.0018.09.2	PISTON DIA.78	4
15	80.3247.50.2	O-RING 3,53x28,17	1	53	80.0021.00.2	RING DIA.15	8
15	80.3247.60.2	O-RING 3,53x28,17 (KIT VITON)	1	54	85.2006.70.2	PISTON PIN DIA.15	4
16	27.0037.46.2	SPACER	1	55	82.0120.00.2	WING NUT G.2"	1
17	85.2576.00.2	CAP G.3/8	2	56	84.0596.00.2	90° ELBOW CONNECTOR DIA.45-1,77"	1
18	28.0074.32.2	MANIFOLD PIPE WITH HOLE G.3/8	2	56	84.1642.80.2	STRAIGHT CONNECTOR D.45-1,77" (optional)	1
19	28.0071.32.2	MANIFOLD PIPE G.1"	2	56	84.1643.00.2	STRAIGHT CONNECTOR D.50-1,96 (optional)	1
20	86.2960.00.2	SCREW M8x65 UNI5931	16	56	84.0610.00.2	90° ELBOW CONNECTOR DIA.50-1,96 (OPT.)	1
21	84.3685.50.2	WASHER DIA.8,2x15x1,5	16	57	80.3209.10.2	O-RING 2,62x40,95	2
22	80.3250.00.2	O-RING 3,53x31,34	8	58	28.0072.32.2	MANIFOLD PIPE G.2"	1
22	80.3250.10.2	O-RING 3,53x31,34 (KIT VITON)	8	59	28.0070.32.2	INLET-OUTLET MANIFOLD PIPE	3
23	80.3219.10.2	O-RING 3,0x30	1	60	28.0021.61.2	MOUNTING RAIL	2
23	80.3219.15.2	O-RING 3,0x30 (KIT VITON)	1	61	86.3277.00.2	SCREW M10x30 UNI5931	6
24	83.5089.00.2	NIPPLES G.1"-G.1 1/4	1	62	24.3016.97.3	SAFETY VALVE 15bar (OPTIONAL)	1
25	80.3219.00.2	O-RING 3,0x25	1	63	62.0025.32.2	HEAD	4
26	84.0542.40.2	90° ELBOW CONNECTOR DIA.25-1"	1	64	84.3844.50.2	WASHER DIA.12,2x21x2,5	16
26	84.0560.00.2	90° ELBOW CONNECTOR DIA.30-1,18" (OPT.)	1	65	86.4068.00.2	SCREW M12x75 UNI5931	16
26	84.0565.00.2	90° ELBOW PIPE FITTING DIA.32-1,25" (OPT.)	1	66	80.1369.00.2	RING DIA.52	1
27	82.0067.50.2	WING NUT G.1 1/4	1	73	86.2588.00.2	SCREW TCEI M8x20	8
28	82.4079.00.2	GASKET DIA.13,2x17x1 COPPER	1	74	31.1724.46.2	COVER	1
29	86.3694.50.2	CAP M12	1	75	80.3210.20.2	O-RING DIA.2,62x60	1
30	28.0003.09.2	CRANKCASE	1	76	31.1725.07.2	CENTRAL COVER	1
31	80.3314.00.2	O-RING 4,5x40	8	77	80.2191.10.2	OIL SEAL DIA. 45x62x7	1
31	80.3314.50.2	O-RING 4,5x40 (KIT VITON)	8	78	81.2946.00.2	BEARING 50x80x16	1
32	28.0229.32.2	VALVE ASSY SPACER	4	79	62.0108.26.2	HOLLOW SHAFT VC VERSION	1